

PRESS RELEASE

Source: Tokyo Institute of Technology

Subject line: ***Lean and mean: Maximizing 5G communications with an energy-efficient relay network***

Scientists at Tokyo Institute of Technology (Tokyo Tech) have developed a wirelessly powered relay network for 5G systems. The proposed battery-free communication addresses the challenges of flexible deployment of relay networks. This design is both economical and energy-efficient. Such advances in 5G communications will create tremendous opportunities for a wide range of sectors.

The ever-increasing demand for wireless data bandwidth shows no sign of slowing down in the near future. Millimeter wave, a short wavelength spectrum, has shown great potential in 5G communications and beyond. To leverage high-capacity millimeter-wave frequencies, phased-array antennas (antenna elements that work together to boost signal strength in a specific direction) are being adapted. However, the current use case is confined to line-of-sight propagation.

As a result, relay nodes are considered for non-line-of-sight communications (Figure 1). While relaying can provide improved bandwidth, coverage, and reliability, the flexible deployment of a relay network poses some challenges. The most significant challenge in relay networks is power supply. A typical relay node has its own power supply unit or is connected to an external power source.

Fortunately, a team of scientists from Tokyo Tech, led by Prof. Kenichi Okada, have proposed a wirelessly-powered 28-GHz phased-array relay transceiver for the 5G network. Their work is scheduled for presentation in the [2021 Symposia on VLSI Technology and Circuits](#), an international conference where emerging trends and novel concepts on semiconductor technology and circuits are explored.

A vector-summing backscattering technique is used to realize the proposed design. The transmitter works as a backscatter with 24GHz local oscillator (LO) and 4GHz intermediate frequency (IF) signals (Figure 2). Okada elaborates, "Backscatter communication makes it possible to harvest energy from incident signals and reflects back parts of the same signals while modulating the data. In this design, backscatter up-converts the 5G New Radio (5G NR) spectrum at 4GHz and transmits at 28GHz." The transmitter also acts as a phase shifter, allowing it to alter the phase of an incoming signal. The backscattering and phase-shifting capabilities of the transmitter facilitate beamforming, wherein an array of antennas can be controlled to transmit signals in a specific direction. As a result, information is transferred more efficiently with less interference.

The receiver and rectifier operation is another critical feature of the transceiver. Passive phase shifters and power combiners (which combine power fed at multiple ports) are used to boost the received signal power for wireless power transfer (WPT). The proposed rectifier

acts as a self-heterodyne mixer. In other words, the rectifier splits and recombines an incoming beam with a modulated version of itself. It also works as a full-wave rectifier with the 24 GHz WPT signal.

The entire phased-array relay transceiver is configured in an area as small as 1.8 mm² (Figure 3). In the receive mode, the wirelessly powered 4x8 array module produces 3.1 mW of power. In the transmit mode, it produces -2.2 dBm of saturated Equivalent Isotropic Radiated Power (EIRP), which is the output power radiated from an antenna in a single direction. The vector-summing backscatter covers a 360° phase range with 7-bit phase resolution while consuming just 0.03 mW in both transmit and receive mode.

Okada excitedly concludes, "The proposed battery-free transceiver enhances 5G connectivity by serving as a repeater between indoor and outdoor environments. This, in turn, will improve user experiences and create new opportunities for operational efficiency in internet-of-things, industrial automation, and new communication services."

Talk about efficiency personified!

Reference

Authors: Michihiro Ide¹, Atsushi Shirane¹, Kiyoshi Yanagisawa¹, Dongwon You¹, Jian Pang¹, and Kenichi Okada^{1,*}

Session: Session 11 Advanced Wireless for 5G, C11-1 (June 17,8:40,JST)

Session Title: A 28-GHz Phased-Array Relay Transceiver for 5G Network Using Vector-Summing Backscatter with 24-GHz Wireless Power and LO Transfer

Conference: [2021 Symposia on VLSI Technology and Circuits](#)

Affiliations: ¹Tokyo Institute of Technology, Tokyo, Japan

*Corresponding author's email: okada@ee.e.titech.ac.jp

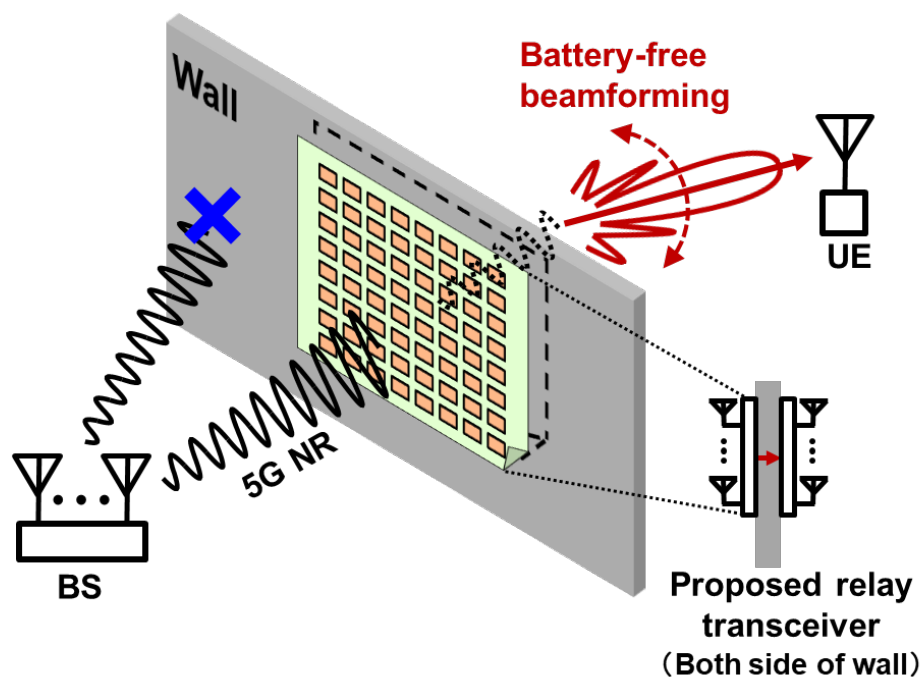

Figure 1. Proposed phased-array relay transceiver system for 5G New Radio

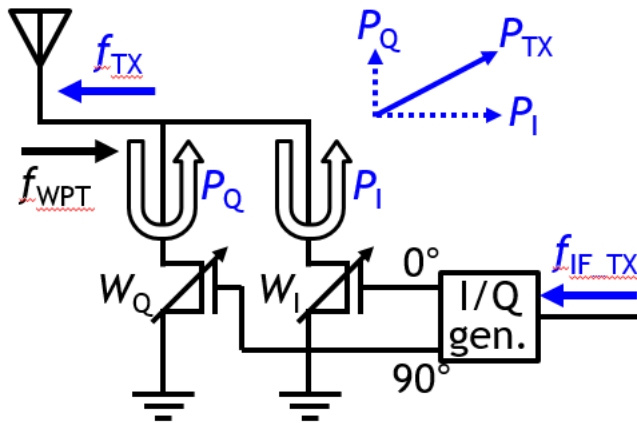

Figure 2. Proposed vector-summing backscattering

The vector-summing backscatter up-converts 4GHz I/Q signal and transmits at 28GHz.

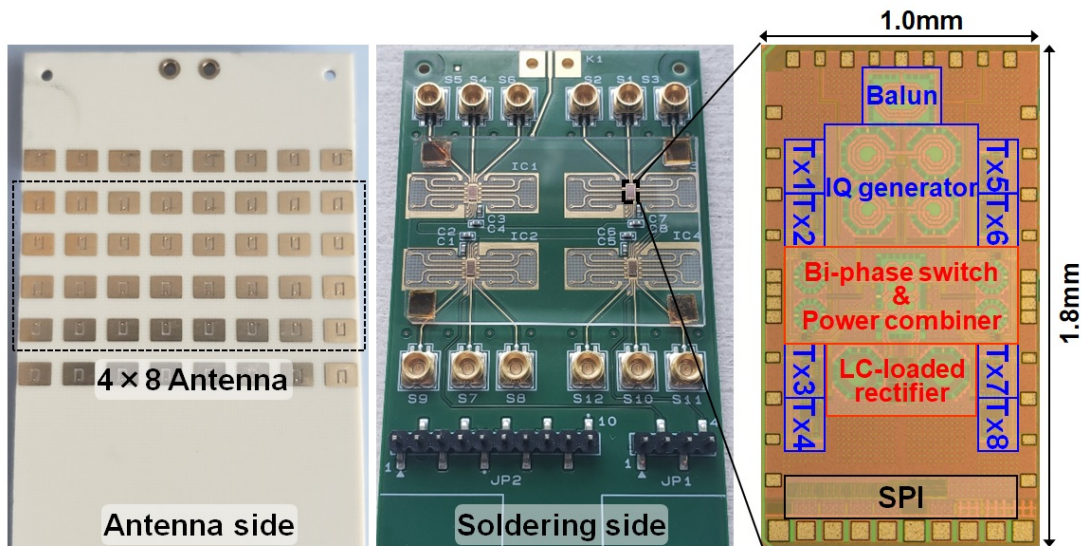

Figure 3. Chip micrograph of 4x8 phased-array relay module implemented by 65-nm CMOS
The proposed chip is manufactured using a standard 65-nm CMOS technology, and the 4X8 element phased-array relay module is composed by the four chips.

Related Links

Researchers develop a compact 28-GHz transceiver supporting dual-polarized MIMO
<https://www.titech.ac.jp/english/news/2020/047242>

Gearing up for 5G: A miniature, low-cost transceiver for fast, reliable communications
<https://www.titech.ac.jp/english/news/2019/043432>

Greater Connectedness in Remote Areas: A Ka-band Transceiver for Satellite Communications
<https://www.titech.ac.jp/english/news/2020/047487>

Contact

Emiko Kawaguchi
Public Relations Division,
Tokyo Institute of Technology
media@jim.titech.ac.jp
+81-3-5734-2975

About Tokyo Institute of Technology

Tokyo Tech stands at the forefront of research and higher education as the leading university for science and technology in Japan. Tokyo Tech researchers excel in fields ranging from materials science to biology, computer science, and physics. Founded in 1881, Tokyo Tech hosts over 10,000 undergraduate and graduate students per year, who develop into scientific leaders and some of the most sought-after engineers in industry. Embodying the Japanese philosophy of “monotsukuri,” meaning “technical ingenuity and innovation,” the Tokyo Tech community strives to contribute to society through high-impact research.

<https://www.titech.ac.jp/english/>