

## PRESS RELEASE

Sources:

Tokyo Institute of Technology

NEC Corporation

For immediate release: June 17, 2020

Subject line: **Researchers develop a compact 28 GHz transceiver supporting dual-polarized MIMO**

**— Study contributes to driving advances in 5G —**

(Tokyo, June 17 2020) **Researchers at Tokyo Institute of Technology (Tokyo Tech) and NEC Corporation have jointly developed a 28 GHz phased-array<sup>[1]</sup> transceiver supporting dual-polarized MIMO<sup>[2]</sup> for fifth-generation mobile communications system (5G) radio units. Advances in 5G will benefit an array of industries ranging from healthcare, manufacturing and transportation to education and entertainment that require high bandwidth and high-quality connectivity.**

As countries launch or prepare for 5G services, researchers are continuing to step up efforts to facilitate deployment of 5G infrastructure. Dual-polarized phased-array transceivers are an attractive class of antenna systems that can transmit data simultaneously through horizontal and vertical-polarized waves. Numerous studies have shown that dual-polarized MIMO can improve the data rate and spectrum efficiency in 5G radio units. However, one problem encountered with these systems is cross-polarization leakage<sup>[3]</sup>, which results in degradation of signal quality especially in the millimeter wave band.

Now, [Kenichi Okada](#)'s Lab at Tokyo Tech's Department of Electrical and Electronic Engineering and NEC corporation in Japan have developed a transceiver capable of canceling cross-polarization interference using a built-in so-called horizontal and vertical (H/V) canceller. Tests have shown that the error vector magnitude<sup>[4]</sup> in 256QAM<sup>[5]</sup> can be improved from 7.6% to a more desirable, lower figure of 3.3% using this new leakage cancellation technique. "The cancellation signals are generated for horizontal and vertical polarization at the transmission side so that it can cancel the cross-polarization leakage caused by all through the transmitter/receiver chip, package, printed circuit board and antenna," the researchers say.

The transceiver was fabricated using low-cost, mass-producible silicon CMOS<sup>[6]</sup> technology, occupying an area of just 16 mm<sup>2</sup>. The researchers anticipate that the new circuitry could be installed in a wide range of applications that will be enabled by 5G in the future. Importantly, they point out that their transceiver will improve spectrum efficiency while keeping equipment size and set-up costs to a minimum.

The findings are being presented at the [2020 Symposia on VLSI Technology and Circuits](#) (VLSI 2020), held online from 14 June. The paper has also been selected as one of the technical highlights at the conference.

This research is supported by the Ministry of Internal Affairs and Communications in Japan (JPJ000254).

---

### Images

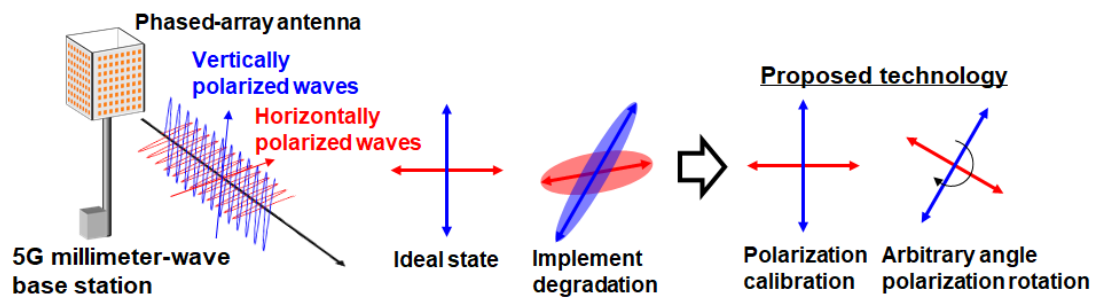

**Figure 1. The new transceiver is designed to limit signal degradation**  
An illustration of leakage cancellation between polarization signals and arbitrary angle polarization rotation.

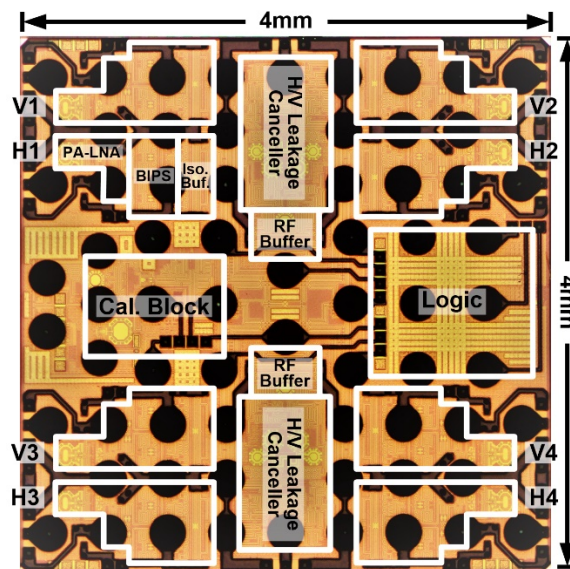

**Figure 2. Phased-array radio for polarization MIMO.**

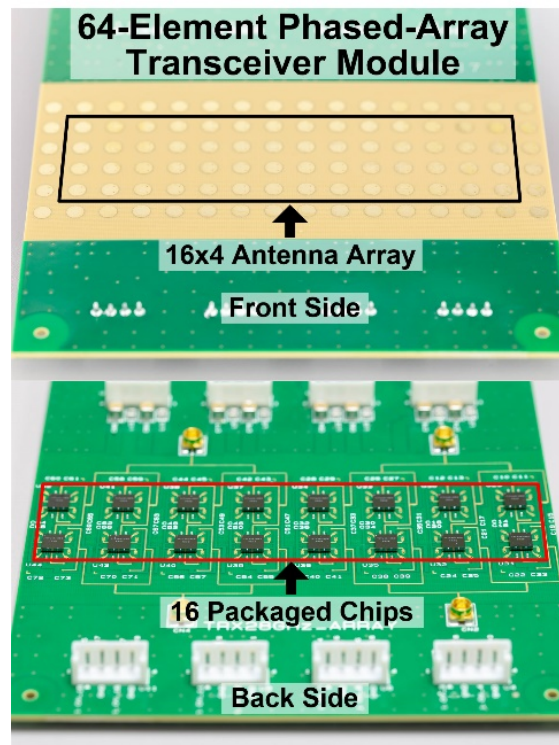

Figure 3. Printed circuit board with 64 antenna elements.

### Technical terms

[1] phased-array: Describing an electrically steerable array of antennas.

[2] Dual-polarized MIMO: Dual-polarized multiple-input multiple-output (MIMO) refers to an antenna system for wireless communications that can improve transmission capacity through the use of a plurality of antennae that transmit signals simultaneously.

[3] cross-polarization leakage: A type of signal leakage caused by horizontal and vertical-polarized signals interfering with each other.

[4] Error vector magnitude: A measure of the level of interference, calculated by the difference between the ideal transmitted signal and the actual received signal.

[5] 256QAM: The highest digital modulation method for converting digital data into radio waves and electric signals.

[6] CMOS: Complementary metal-oxide-semiconductor, the main processing method for creating integrated circuits.

### References

Technology Session (Video) : [CF2 – RF & mm-Wave Circuits](#)

Session Title : A 28-GHz CMOS Phased-Array Beamformer Supporting Dual-Polarized MIMO with Cross-Polarization Leakage Cancellation

Authors: Pang, J. *et al.*

Conference: 2020 Symposia on VLSI Technology and Circuits

<https://vlsisymposium.org/>

#### Affiliations

<sup>1</sup> Department of Electrical and Electronic Engineering, Tokyo Institute of Technology, Tokyo, Japan

<sup>2</sup> NEC Corporation, Kawasaki, Japan

Author's email: [okada@ee.e.titech.ac.jp](mailto:okada@ee.e.titech.ac.jp)

#### Related links

[A more accurate, low-cost 39 GHz beamforming transceiver for 5G communications | Tokyo Tech News](#)

[Gearing up for 5G: A miniature, low-cost transceiver for fast, reliable communications | Tokyo Tech News](#)

[New 28-GHz transceiver paves the way for future 5G devices | Tokyo Tech News](#)

[Speeding up adoption of 5G! Wireless transmission speeds of 120 Gbps achieved | Tokyo Tech News](#)

[Tokyo Tech and Fujitsu Achieve Wireless Transmission Speeds of 56 Gbps, World's Fastest | Tokyo Tech News](#)

[Kenichi Okada HP](#)

#### Contact

Emiko Kawaguchi

Public Relations Group,

Tokyo Institute of Technology

Email: [media@jim.titech.ac.jp](mailto:media@jim.titech.ac.jp)

+81-3-5734-2975

#### About Tokyo Institute of Technology

Tokyo Tech stands at the forefront of research and higher education as the leading university for science and technology in Japan. Tokyo Tech researchers excel in fields

ranging from materials science to biology, computer science, and physics. Founded in 1881, Tokyo Tech hosts over 10,000 undergraduate and graduate students per year, who develop into scientific leaders and some of the most sought-after engineers in industry. Embodying the Japanese philosophy of “monotsukuri,” meaning “technical ingenuity and innovation,” the Tokyo Tech community strives to contribute to society through high-impact research.

<https://www.titech.ac.jp/english/>

### **About NEC Corporation**

NEC Corporation has established itself as a leader in the integration of IT and network technologies while promoting the brand statement of “Orchestrating a brighter world.” NEC enables businesses and communities to adapt to rapid changes taking place in both society and the market as it provides for the social values of safety, security, fairness and efficiency to promote a more sustainable world where everyone has the chance to reach their full potential. For more information, visit NEC at <http://www.nec.com>.